

AEROLINE®

CONNECTION TECHNOLOGY
FOR SOLAR THERMAL SYSTEMS



TECHNICAL
INSULATION

TECHNICAL INSULATION

by



www.nmc-insulation.com

CONTENTS

AEROLINE® solar	7
Pressure drops	10
Conception	11
Tolerance	12
AEROLINE® cu split 100	14
AEROLINE® cu pro 100	16
Accessories AEROLINE® cu	18
AEROLINE® inox split 100	20
AEROLINE® inox pro 100 / inox pro gs	22
AEROLINE® inox rapid basic	24
Accessories Isiclick®	26
Accessories AEROLINE® inox	28
SOLAR-TUBE® eco	30
SOLAR-TUBE® eco combi	32
Accessories SOLAR-TUBE® eco	34
AEROLINE® inox rapid classic	36
AEROLINE® inox rapid pro	38
AEROLINE® inox rapid pro gs	40
Notes	43





GENERAL INFORMATION

- Prices valid from 1 January 2024.
- All previous price lists are hereby superseded.
- Subject to errors and misprints. Recommended price plus statutory VAT.
- All deliveries are subject to our general terms and conditions of delivery, service and payment.
- Delivery only in complete packaging units.
- Upon receipt, check that the goods are complete.
- Any discrepancies must be noted on the delivery note and signed by the driver.
- The costs of returning the goods will be charged to you.
- Returns of goods must be notified.



AEROLINE[®]

SAVE
ENERGY
AND
PRESERVE
THE
ENVIRONMENT

AEROLINE®

solar

THE IDEAL CONNECTION SOLUTION FOR SOLAR THERMAL ENERGY.

Field-proven technology and continuous product development are the basis for AEROLINE® Solar pipe systems. The pre-insulated systems with feed and return are easy to connect to any common solar components – without special tools, soldering, welding etc.

Your advantage: Reduced costs, faster assembly, excellent thermal insulation.

THE HIGHLIGHTS AT A GLANCE:



MINIMUM BENDING RADIUS
Space saving and flexible in narrow space installations.



ROBUST JACKET
A special feature for outdoor use: the robust AEROLINE® PRO mesh protection.



LOWEST THERMAL LOSS
The thermal loss of the twin tube system AEROLINE® split 100 (DN 16/DN 20) is as low as that of 2 single laid pipes completed with 26 mm thermal insulation.

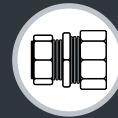

METAL-TO-METAL SEALING
Safe connection with ISICLICK®.



HIGH TEMPERATURE RESISTANCE
Permanent temperature resistance up to 150 °C, short term up to 175 °C.



FAST AND SIMPLE ASSEMBLY
The complete line set is quick and easy to install – even in the tightest spaces



NO SPECIAL TOOLS
ISICLICK® connections are just ingenious, no special tools are required.

THE RIGHT THERMAL INSULATION MATTERS!

The CFC-free insulation of the AEROLINE® systems is made of a special AEROFLEX® EPDM rubber, and guarantees optimum energy efficiency. The excellent weather resistance allows outdoor installation without further protection measures.

THE HIGHLIGHTS AT A GLANCE:

- Excellent handling characteristics
- Many years of experience in heating, air conditioning and solar application
- High temperature resistance
- Outdoor installation
- Highest insulation values
- Short term temperature resistance up to 175 °C
- UV and weather resistance
- Thermal conductivity: 0,038 W/mK at 40 °C
- No embrittlement of copper and stainless steel tubes (DIN 1988 Part 200)
- Quality control by an independent material inspection institute



AEROLINE® SOLAR THERMAL TWIN TUBE SYSTEMS – EXTREMELY SPACE SAVING

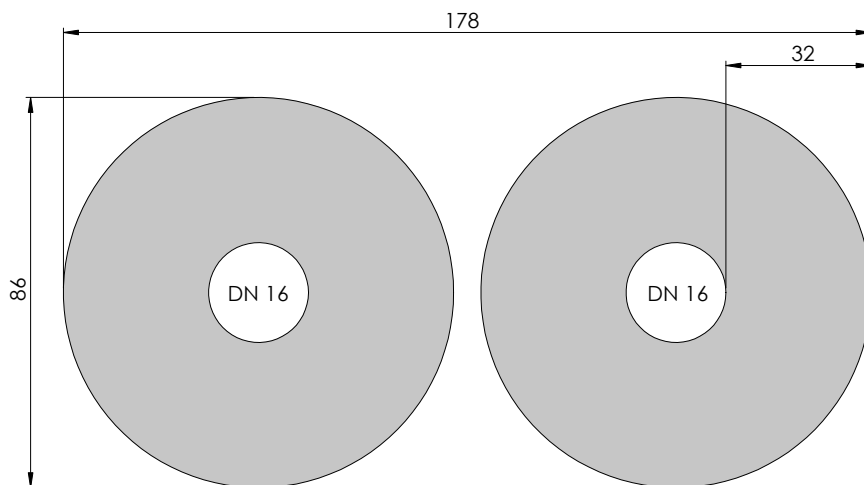

Single tube connection with high temperature rubber 0,042 W/mK at 40 °C
Surface area approx. 152 cm²

OPTIMUM GEOMETRY AND VERY LOW THERMAL CONDUCTIVITY

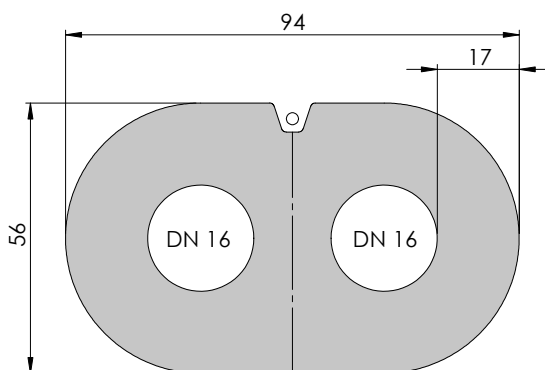

- AEROLINE® inox split 100 twin tube system with optimal insulation
- Surface area approx. 53 cm² (approx. -65 %)



Exemplary temperature run

AEROLINE® COMBINES THE PRACTICAL WITH THE REGULATIONS

All products in the AEROLINE® product range comply with the current standards. The layouts of the products were realised by the Research Institute for Thermal Protection in Munich (FIW) to guarantee installers and customers to work with optimized products.

PRESSURE DROPS

AEROLINE® inox & AEROLINE® cu

These diagrams apply to 1 linear metre of straight laid twin tubes and a mixture of water-tyfocor L (60/40) at a temperature of 40 °C.

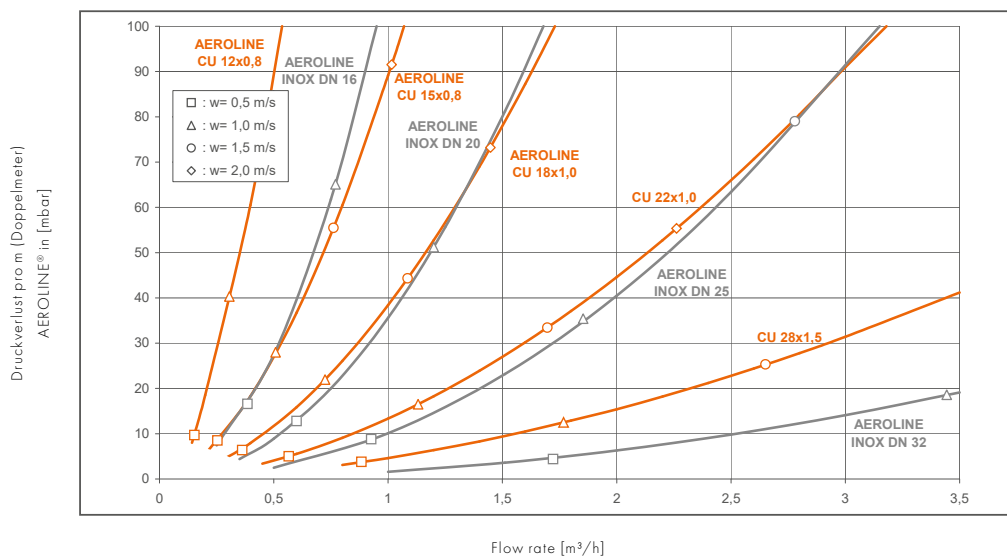

AEROLINE® inox rapid

These diagrams apply to 1 linear metre of straight laid tube and a mixture of water-tyfocor L (60/40) at a temperature of 40 °C

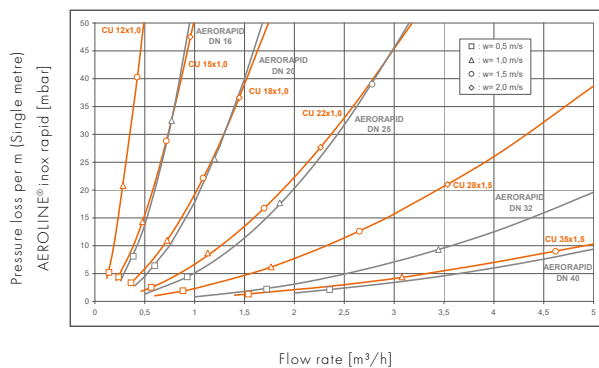

These diagrams apply to 1 linear metre of straight laid tube with water at a temperature of 40 °C

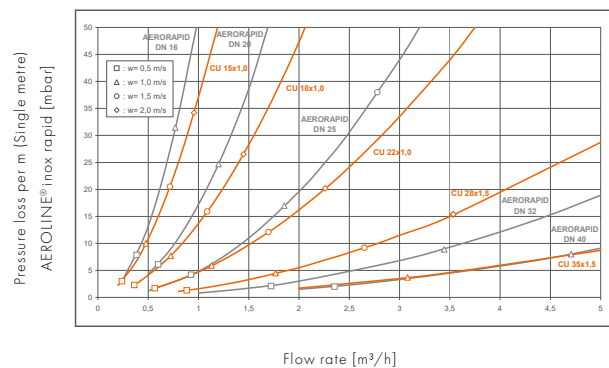

Please consider the total pressure drops of all components (collector, heat exchanger, stop valves, check valves, pipe bends, etc.)

CONCEPTION

<p>High-Flow solar systems Flow rate 40 l/m²h with EC-high efficiency pump Wilco Stratos ECO-ST 25/1-5 or pump Wilo Star-ST 25/6 respectively Grundfos UPS Solar 25-60</p>	<p>Maximum length of the line set (twin tube in metres) at</p>	<p>Collector surface</p>
---	--	--------------------------

AEROLINE® cu

AEROLINE® cu 12 mm	10 m	7 m ²
	15 m	6 m ²
	25 m	5 m ²
AEROLINE® cu 15 mm	10 m	12 m ²
	15 m	10 m ²
	25 m	8 m ²
AEROLINE® cu 18 mm	10 m	18 m ²
	15 m	16 m ²
	25 m	14 m ²

AEROLINE® inox

AEROLINE® inox DN 16	10 m	12 m ²
	15 m	10 m ²
	25 m	8 m ²
AEROLINE® inox DN 20	10 m	20 m ²
	15 m	18 m ²
	25 m	16 m ²
AEROLINE® inox DN 25	10 m	32 m ²
	15 m	28 m ²
	25 m	24 m ²
AEROLINE® inox DN 32	10 m	58 m ²
	15 m	50 m ²
	25 m	44 m ²

Special note:

This reference conception only serves as a pre-selection of your system and does not replace any pressure drop calculation for the complete system. Please consider the total pressure drop of all components (collector, heat exchanger, stop valves, check valves, tube elbows, etc.). For Low-Flow-systems (flow rate 20 l/m²h with EC-high efficiency pump Wilo Stratos ECO-ST 25/1-5 or pump Wilo Star-ST 25/6 respectively Grundfos UPS Solar 25-60) the collector surface may be almost doubled. For drain-back-systems please follow the manufacturer's instructions.

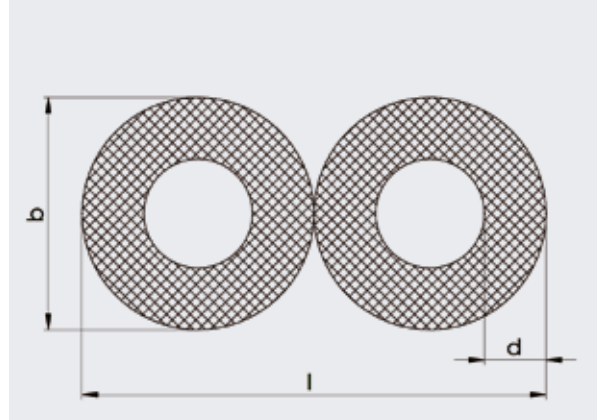

TOLERANCES BASED ON DIN EN 14304.

SOLAR-TUBE® | eco

Dimension	Insulation thickness (d)	Length (l)	Width (b)
SOLAR-TUBE® eco DN 16	13 mm	98 mm	49 mm
SOLAR-TUBE® eco DN 20	13 mm	110 mm	55 mm
SOLAR-TUBE® eco DN 25	13 mm	124 mm	62 mm

Dimension	Inner diameter	Outer diameter	Maximum operation pressure at 200 °C	Minimum bending radius
SOLAR-TUBE® eco DN 16	16,4 mm	21,1 mm	9,8 bar	25 mm
SOLAR-TUBE® eco DN 20	20,4 mm	26,7 mm	6,1 bar	30 mm
SOLAR-TUBE® eco DN 25	25,2 mm	31,7 mm	6,1 bar	35 mm

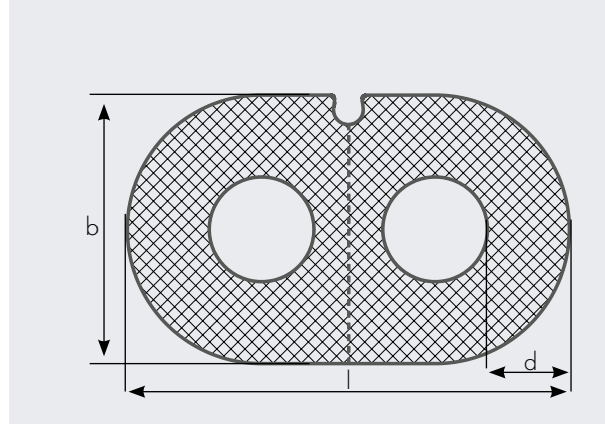

AEROLINE®

Dimension	Category	Insulation thickness (d)	Length (l)	Width (b)
AEROLINE® cu				
AEROLINE® cu 12 mm	cu split 100	15 mm	67 mm	42 mm
	cu pro 100	15 mm	67 mm	42 mm
AEROLINE® cu 15 mm	cu split 100	15 mm	74 mm	45 mm
	cu pro 100	15 mm	74 mm	45 mm
AEROLINE® cu 18 mm	cu split 100	16 mm	82 mm	51 mm
	cu pro 100	16 mm	82 mm	51 mm
AEROLINE® inox				
AEROLINE® inox DN 16	inox split 100	17 mm	95 mm	57 mm
	inox pro 100	17 mm	95 mm	57 mm
AEROLINE® inox DN 20	inox split 100	18 mm	107 mm	64 mm
	inox pro 100	18 mm	107 mm	64 mm
AEROLINE® inox DN 25	inox split 100	25 mm	134 mm	85 mm
	inox pro GS	25 mm	134 mm	85 mm
AEROLINE® inox DN 32	inox pro GS	25 mm	160 mm	95 mm

Dimension	Inner diameter	Outer diameter	Maximum operation pressure at 200 °C	Minimum bending radius
AEROLINE® cu				
AEROLINE® cu 12 mm	10,4 mm	12,0 mm	53 bar	72 mm
AEROLINE® cu 15 mm	13,4 mm	15,0 mm	42 bar	90 mm
AEROLINE® cu 18 mm	16,0 mm	18,0 mm	44 bar	108 mm
AEROLINE® inox				
AEROLINE® inox DN 16	16,5 mm	20,4 mm	11 bar	40 mm
AEROLINE® inox DN 20	20,6 mm	24,8 mm	11 bar	50 mm
AEROLINE® inox DN 25	25,6 mm	30,5 mm	10 bar	60 mm
AEROLINE® inox DN 32	32,4 mm	39,9 mm	6 bar	55 mm
AEROLINE® inox DN 40	40,7 mm	49,9 mm	4,9 bar	60 mm

AEROLINE®

cu split 100

**FAST-ASSEMBLY COPPER PIPING SYSTEMS FOR
A COMPLETELY SAFE CONNECTION BETWEEN SOLAR
COLLECTORS AND STORAGE TANK**

TECHNICAL SPECIFICATIONS

SHEATHING

MATERIAL	Polyolefin film Very good ozone resistance, UV-resistant
----------	---

COPPER TUBES

MATERIAL	R220 (according to DIN EN 12449)
----------	----------------------------------

SENSOR CABLE

2 x 0,75 mm² VDE 0295, Silicone, class 5

INSULATION MADE OF EPDM

MATERIAL	Light, flexible, closed-cell, synthetic rubber. Free of PVC and CFC (according to legal requirements). No embrittlement of copper and stainless steel pipes (DIN 1988 Part 200) Dimensions and tolerances according to DIN EN 14304
TEMPERATURE RANGE	+150 °C, short-term up to +175 °C (stagnation temperature of collectors)
THERMAL CONDUCTIVITY	0,036 W/mK at 0 °C 0,038 W/mK at 40 °C
FIRE BEHAVIOUR	Euro class E (DIN EN 13501-1)

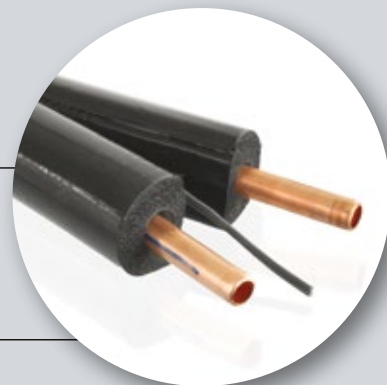



AEROLINE®

cu split 100

Reference	SAP	m/	RBG	Price per metre - Copper price* in EUR per kg									
				2,01-3,00	3,01-4,00	4,01-5,00	5,01-6,00	6,01-7,00	7,01-8,00	8,01-9,00	9,01-10,00	10,01-11,00	
PIPE DIMENSION 12 x 0,8 mm													
12 x 15/10 m	3032017	10	AR1	37,89	39,48	41,08	42,68	44,27	45,87	47,46	49,06	50,66	
12 x 15/15 m	3032018	15	AR1	36,13	37,65	39,17	40,69	42,21	43,73	45,25	46,77	48,29	
12 x 15/20 m	3032019	20	AR1	35,63	37,13	38,63	40,13	41,63	43,13	44,63	46,13	47,63	
12 x 15/25 m	3032020	25	AR1	34,79	36,26	37,72	39,18	40,64	42,1	43,57	45,03	46,49	
PIPE DIMENSION 15 x 0,8 mm													
15 x 15/10 m	3032029	10	AR1	42,23	44,22	46,21	48,2	50,19	52,18	54,17	56,16	58,15	
15 x 15/15 m	3032030	15	AR1	40,34	42,24	44,14	46,04	47,94	49,84	51,74	53,64	55,54	
15 x 15/20 m	3032031	20	AR1	39,84	41,72	43,59	45,47	47,35	49,22	51,1	52,97	54,85	
15 x 15/25 m	3032032	25	AR1	39,41	41,27	43,13	44,98	46,84	48,69	50,55	52,41	54,26	
PIPE DIMENSION 18 x 1 mm													
18 x 15/10 m	3032041	10	AR1	49,76	52,73	55,7	58,67	61,64	64,61	67,58	70,55	73,52	
18 x 15/15 m	3032042	15	AR1	47,95	50,81	53,67	56,53	59,39	62,25	65,11	67,97	70,83	
18 x 15/20 m	3032043	20	AR1	47,01	49,81	52,62	55,42	58,23	61,03	63,83	66,64	69,44	
18 x 15/25 m	3032044	25	AR1	46,58	49,35	52,13	54,91	57,68	60,46	63,23	66,01	68,79	

Delivery: 2-7 working days ex-works (applies to all references)

*Copper price: based on prices from the London Metal Exchange (LME), including industrial surcharges

AEROLINE®

cu pro 100

DESIGNED FOR FAST-ASSEMBLY PIPING SYSTEMS THAT PROVIDES A COMPLETELY SAFE CONNECTION BETWEEN SOLAR COLLECTORS AND STORAGE TANK. IDEAL FOR OUTDOOR USE, WITH ADDED PROTECTION AGAINST ANIMAL ATTACK.

TECHNICAL SPECIFICATIONS

SHEATHING

MATERIAL Mounting protection made from robust polyester/stainless steel wire mesh
Very good ozone resistance, UV-resistant

COPPER TUBES

MATERIAL R220 (according to DIN EN 12449)

SENSOR CABLE

3 x 0,75 mm² VDE 0295, Silicone, class 5

INSULATION MADE OF EPDM

MATERIAL Light, flexible, closed-cell, synthetic rubber.
Free of PVC and CFC (according to legal requirements). No embrittlement of copper and stainless steel pipes (DIN 1988 Part 200)
Dimensions and tolerances according to DIN EN 14304

TEMPERATURE RANGE +150 °C, short-term up to +175 °C (stagnation temperature of collectors)

THERMAL CONDUCTIVITY 0,036 W/mK at 0 °C
0,038 W/mK at 40 °C

FIRE BEHAVIOUR Euro class E (DIN EN 13501-1)

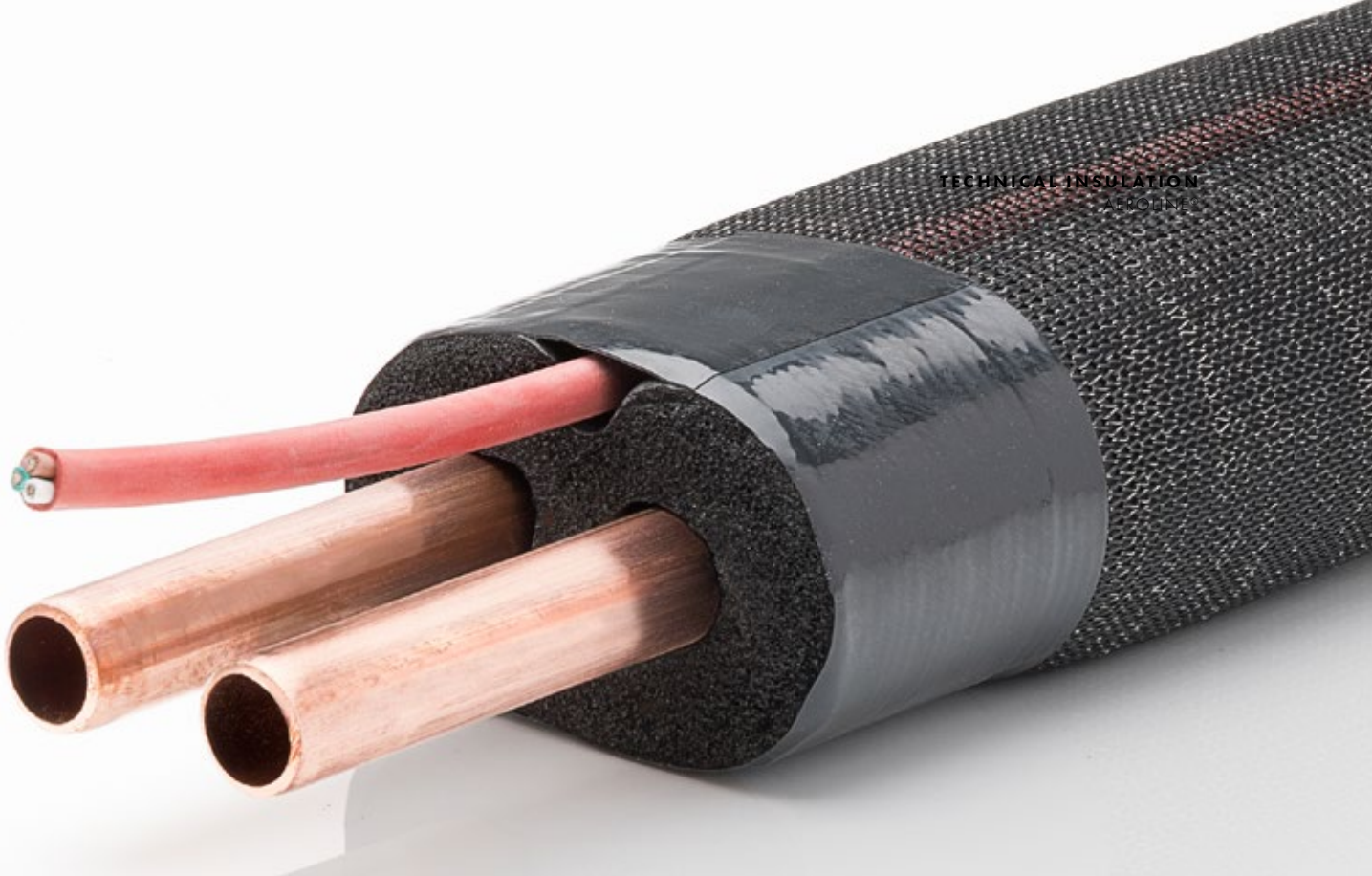

AEROLINE®

cu pro 100

Reference	SAP	m/	RBG	Price per metre - Copper price* in EUR per kg									
				2,01-3,00	3,01-4,00	4,01-5,00	5,01-6,00	6,01-7,00	7,01-8,00	8,01-9,00	9,01-10,00	10,01-11,00	
PIPE DIMENSION 12 x 0,8 mm													
12 x 15/10 m	3032013	10	AR1	42,25	43,85	45,45	47,04	48,64	50,23	51,83	53,43	55,02	
12 x 15/15 m	3032014	15	AR1	40,50	42,02	43,54	45,06	46,58	48,1	49,62	51,14	52,66	
12 x 15/20 m	3032015	20	AR1	40,00	41,50	43,00	44,50	46,00	47,5	49,00	50,50	52,00	
12 x 15/25 m	3032016	25	AR1	39,16	40,62	42,08	43,55	45,01	46,47	47,93	49,39	50,86	
PIPE DIMENSION 15 x 0,8 mm													
15 x 15/10 m	3032025	10	AR1	47,33	49,32	51,31	53,3	55,29	57,28	59,27	61,26	63,25	
15 x 15/15 m	3032026	15	AR1	45,43	47,33	49,23	51,13	53,03	54,93	56,83	58,73	60,63	
15 x 15/20 m	3032027	20	AR1	44,94	46,81	48,69	50,56	52,44	54,32	56,19	58,07	59,94	
15 x 15/25 m	3032028	25	AR1	44,51	46,36	48,22	50,08	51,93	53,79	55,64	57,5	59,36	
PIPE DIMENSION 18 x 1 mm													
18 x 15/10 m	3032037	10	AR1	54,13	57,10	60,07	63,04	66,01	68,98	71,95	74,92	77,89	
18 x 15/15 m	3032038	15	AR1	52,31	55,17	58,03	60,89	63,75	66,61	69,47	72,33	75,19	
18 x 15/20 m	3032039	20	AR1	51,38	54,18	56,99	59,79	62,59	65,40	68,20	71,01	73,81	
18 x 15/25 m	3032040	25	AR1	50,94	53,72	56,50	59,27	62,05	64,82	67,60	70,38	73,15	

Delivery: 2-7 working days ex-works (applies to all references)

*Copper price: based on prices from the London Metal Exchange (LME), including industrial surcharges

ACCESSORIES AEROLINE® CU



1

Straight screw fastening with clamping ring

Reference	SAP	Pc./📦	RBG	€/Pc.
12 x 12 mm	3033006	1	AS1	9,19
15 x 15 mm	3033007	1	AS1	9,64
18 x 18 mm	3033008	1	AS1	10,44
22 x 22 mm	3033009	1	AS1	12,71



2

Clamping ring reduces the screwing requirement

Reference	SAP	Pc./📦	RBG	€/Pc.
15 x 12 mm	3032975	1	AS1	6,92
18 x 15 mm	3032976	1	AS1	12,18
22 x 18 mm	3033011	1	AS1	12,18



3

Screw connection with external thread x clamping ring

Reference	SAP	Pc./📦	RBG	€/Pc.
3/4" x 15 mm	3033000	1	AS1	11,90
3/4" x 18 mm	3033001	1	AS1	11,90
3/4" x 22 mm	3033002	1	AS1	10,44
1" x 22 mm	3033003	1	AS1	10,96
1 1/4" x 28 mm	3033004	1	AS1	34,95

Collector with pipe end

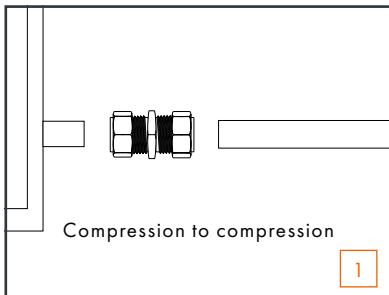

Collector with pipe end

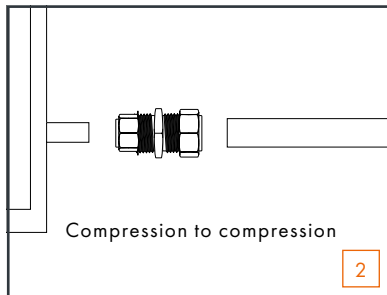

Collector with union nut, flat sealing

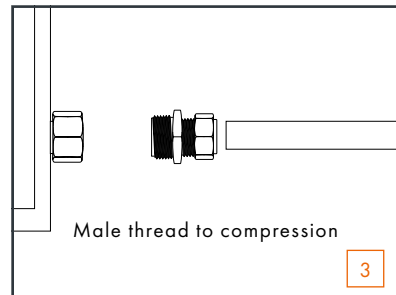



4

Clamping ring angle 90°

Reference	SAP	Pc./📦	RBG	€/Pc.
18 x 18 mm	3032922	1	AS1	9,99
22 x 22 mm	3032923	1	AS1	10,96



5

T-shaped clamping ring

Reference	SAP	Pc./📦	RBG	€/Pc.
18 x 18 x 18 mm	3032924	1	AS1	14,37
22 x 22 x 22 mm	3032999	1	AS1	15,68



Mounting material cu

Reference	Description	SAP	Pc./📦	RBG	€/Pc.
Size 0 (for CU12)	4 oval clips	3035472	1	AS2	16,50
	4 hanger bolts M8 x 80				
	4 dowels S10				
Size 1 (for CU15/18)	4 oval clips	3035470	1	AS2	17,64
	4 hanger bolts M8 x 80				
	4 dowels S10				
Size 2 (for CU18 PRO)	4 oval clips	3035471	1	AS2	20,05
	4 hanger bolts M8 x 80				
	4 dowels S10				

Collector with male thread, flat sealing

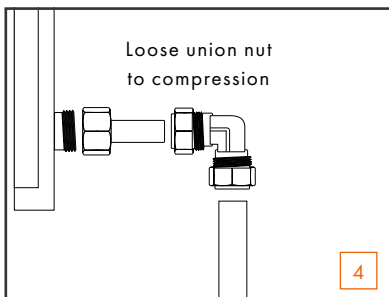

4

Collector with pipe end

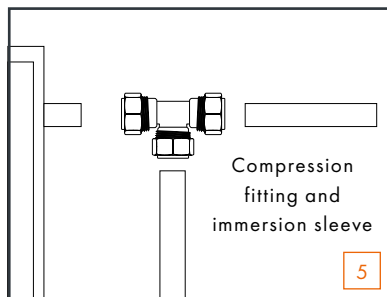

5

AEROLINE®

inox split 100

QUICK, EASY-TO-SEPARATE PIPE SYSTEM FOR A COMPLETELY SAFE CONNECTION TO THE COLLECTOR, SOLAR STATION AND STORAGE TANK. INCLUDES PROTECTIVE FILM TO PREVENT DAMAGE DURING INSTALLATION.

TECHNICAL SPECIFICATIONS

SHEATHING

MATERIAL	Polyolefin film
	Very good ozone resistance, UV-resistant

STAINLESS STEEL CORRUGATED PIPE

MATERIAL	Material No.1.4404 (AISI 316L)
TEMPERATURE RANGE	-270 °C to 600 °C
MAXIMUM PERMISSIBLE OPERATING PRESSURE AT 200 °C	DN 16: 11 bar DN 20: 11 bar DN 25: 10 bar
BURST PRESSURE	Greater than 33 bar

SENSOR CABLE

2 x 0,75 mm² VDE 7507

INSULATION MADE OF EPDM

MATERIAL	Light, flexible, closed-cell, synthetic rubber. Free of PVC and CFC (according to legal requirements). No embrittlement of copper and stainless steel pipes (DIN 1988 Part 200) Dimensions and tolerances according to DIN EN 14304
TEMPERATURE RANGE	+150 °C, short-term up to +175 °C (stagnation temperature of collectors)
THERMAL CONDUCTIVITY	0,036 W/mK at 0 °C 0,038 W/mK at 40 °C
FIRE BEHAVIOUR	Euro class E (DIN EN 13501-1)



AEROLINE®

inox split 100

Reference	SAP	m/🚚	RBG	€/m
DN 16				
16 x 17/10 m	3032066	10	AR2	60,25
16 x 17/15 m	3032067	15	AR2	59,67
16 x 17/20 m	3032068	20	AR2	58,80
16 x 17/25 m	3032069	25	AR2	58,22
16 x 17/50 m	3032070	50	AR2	58,22
DN 20				
20 x 18/10 m	3032092	10	AR2	68,99
20 x 18/15 m	3032093	15	AR2	68,40
20 x 18/20 m	3032094	20	AR2	67,53
20 x 18/25 m	3032095	25	AR2	66,95
20 x 18/50 m	3032098	50	AR2	66,95
DN 25				
25 x 25/10 m	3032115	10	AR2	86,45
25 x 25/15 m	3032116	15	AR2	85,72
25 x 25/20 m	3032117	20	AR2	85,00
25 x 25/25 m	3032118	25	AR2	84,27
25 x 25/50 m	3032120	50	AR2	84,27

Delivery: 2-7 working days ex-works (applies to all references)

AEROLINE®

inox pro 100

inox pro gs

FAST-ASSEMBLY PIPING SYSTEMS FOR A COMPLETELY SAFE CONNECTION BETWEEN SOLAR COLLECTORS AND STORAGE TANK. IDEAL FOR OUTDOOR USE WITH ADDED PROTECTION AGAINST ANIMAL ATTACK.

TECHNICAL SPECIFICATIONS

SHEATHING

MATERIAL	inox pro 100: Mounting protection made from tough polyester/stainless steel mesh
	inox pro gs: Mounting protection made from polyester fabric
	Very good ozone resistance, UV-resistant

STAINLESS STEEL CORRUGATED PIPE

MATERIAL	Material No. 1.4404 (AISI 316L)
TEMPERATURE RANGE	-270 °C to 600 °C
MAXIMUM PERMISSIBLE OPERATING PRESSURE AT 200°C	DN 16: 11 bar DN 25: 10 bar DN 20: 11 bar DN 32: 6 bar
BURST PRESSURE	DN 16/20/25: greater than 33 bar DN 32: greater than 20 bar

SENSOR CABLE

inox pro gs DN 32	2 x 0,75 mm ² VDE 7507
inox pro 100 & inox pro gs DN 25	3 x 0,75 mm ² VDE 0295, Silicone, class 5

INSULATION MADE OF EPDM

MATERIAL	Light, flexible, closed-cell, synthetic rubber. Free of PVC and CFC (according to legal requirements). No embrittlement of copper and stainless steel pipes (DIN 1988 Part 200). Dimensions and tolerances according to DIN EN 14304
TEMPERATURE RANGE	+150 °C, short-term up to +175 °C (stagnation temperature of collectors)
THERMAL CONDUCTIVITY	0,036 W/mK at 0 °C 0,038 W/mK at 40 °C
FIRE BEHAVIOUR	Euro class E (DIN EN 13501-1)



AEROLINE® | inox pro 100

Reference	SAP	m/📦	RBG	€/m
DN 16				
16 x 17/10 m	3032060	10	AR2	65,35
16 x 17/15 m	3032061	15	AR2	64,77
16 x 17/20 m	3032062	20	AR2	63,89
16 x 17/25 m	3032063	25	AR2	63,31
16 x 17/50 m	3032064	50	AR2	62,44
DN 20				
20 x 18/10 m	3032086	10	AR2	74,81
20 x 18/15 m	3032087	15	AR2	74,23
20 x 18/20 m	3032088	20	AR2	73,35
20 x 18/25 m	3032089	25	AR2	72,77
20 x 18/50 m	3032090	50	AR2	71,90

AEROLINE® | inox pro gs

Reference	SAP	m/📦	RBG	€/m
DN 25				
25 x 25/10 m	3032769	10	AR2	95,18
25 x 25/15 m	3032770	15	AR2	94,46
25 x 25/20 m	3032771	20	AR2	93,73
25 x 25/25 m	3032772	25	AR2	93,00
25 x 25/50 m	3032773	50	AR2	92,27
DN 32				
32 x 25/10 m	3032774	10	AR2	157,04
32 x 25/15 m	3032776	15	AR2	155,58
32 x 25/20 m	3032777	20	AR2	154,86
32 x 25/25 m	3032778	25	AR2	154,13

Delivery: 2-7 working days ex-works (applies to all references)

AEROLINE®

inox rapid basic

**HIGH-GRADE STAINLESS STEEL CORRUGATED PIPE.
BENDABLE WITHOUT KINKING!**

TECHNICAL SPECIFICATIONS

STAINLESS STEEL CORRUGATED PIPE

MATERIAL	Material No. 1.4404 (AISI 316L)	
TEMPERATURE RANGE	-270 °C to +600 °C	
MAXIMUM PERMISSIBLE OPERATING PRESSURE AT 200°C	DN 16: 11 bar DN 20: 11 bar DN 25: 10 bar	DN 32: 6 bar DN 40: 4,9 bar
BURST PRESSURE	DN 16/20/25: greater than 33 bar DN 32/40: greater than 20 bar	
CORRUGATION	DN 16-25: flat	



DN 32-40: large



AEROLINE®

inox rapid basic

Reference	SAP	m/📦	RBG	€/m
DN 16				
DN 16, 10 m	3032207	10	AR3	17,17
DN 16, 25 m	3032208	25	AR3	14,70
DN 16, 50 m	3032209	50	AR3	13,83
DN 20				
DN 20, 15 m	3032210	15	AR3	18,63
DN 20, 25 m	3032211	25	AR3	17,90
DN 20, 50 m	3032213	50	AR3	17,17
DN 25				
DN 25, 15 m	3032216	15	AR3	24,01
DN 25, 25 m	3032217	25	AR3	22,12
DN 25, 50 m	3032218	50	AR3	21,54
DN 32				
DN 32, 14 m	3032219	14	AR3	35,37
DN 32, 25 m	3032221	25	AR3	34,52
DN 32, 50 m	3032222	50	AR3	33,18
DN 40				
DN 40, 14 m	3032224	14	AR3	51,38
DN 40, 25 m	3032225	25	AR3	50,21



Rapid basic stainless steel mounting accessory

Reference	Description	SAP	Pc./📦	RBG	€/Pc.
DN 16	4 mounting clamps 4 hanger bolts M8 x 80 4 dowels S10	3032227	1	AS2	13,74
DN 20	4 mounting clamps 4 hanger bolts M8 x 80 4 dowels S10	3032228	1	AS2	14,48
DN 25	4 mounting clamps 4 hanger bolts M8 x 80 4 dowels S10	3032229	1	AS2	17,15
DN 32	4 mounting clamps 4 hanger bolts M8 x 80 4 dowels S10	3032230	1	AS2	17,64
DN 40	4 mounting clamps 4 hanger bolts M8 x 80 4 dowels S10	3032231	1	AS2	20,87

Delivery: 2-7 working days ex-works (applies to all references)

ACCESSORIES ISICLICK®



ISICLICK® with external thread

Type	Description	SAP	Pc./☞	RBG	€/Pc.
DN 16	DN16 x ½" AG	3032938	1	AS1	20,86
DN 16	DN 16 x ¾" AG	3032940	1	AS1	21,65
DN 16	DN 16 x 1" AG	3032947	1	AS1	25,22
DN 20	DN 20 x ¾" AG	3032939	1	AS1	27,87
DN 20	DN 20 x 1" AG	3032948	1	AS1	27,87
DN 25	DN 25 x 1" AG	3032949	1	AS1	71,92



ISICLICK® with internal thread

Type	Description	SAP	Pc./☞	RBG	€/Pc.
DN 16	DN 16 x ½" IG	3032935	1	AS1	20,86
DN 16	DN 16 x ¾" IG	3032937	1	AS1	21,38
DN 16	DN 16 x 1" IG	3032944	1	AS1	22,69
DN 20	DN 20 x ¾" IG	3032936	1	AS1	26,27
DN 25	DN 25 x 1" IG	3032946	1	AS1	55,31



ISICLICK® with clamping ring

Type	Description	SAP	Pc./☞	RBG	€/Pc.
DN 16	DN 16 x clamp ring 18 mm	3032931	1	AS1	26,46
DN 16	DN 16 x clamp ring 22 mm	3032934	1	AS1	22,77
DN 20	DN 20 x clamp ring 22 mm	3032932	1	AS1	28,39
DN 25	DN 25 x clamp ring 22 mm	3032933	1	AS1	70,11

Collector with union nut,
flat sealing

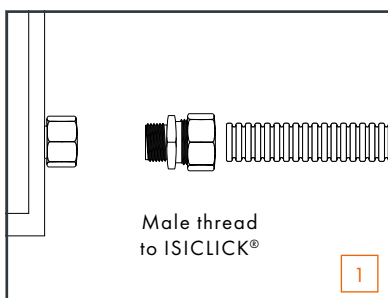

Collector with male thread,
flat sealing

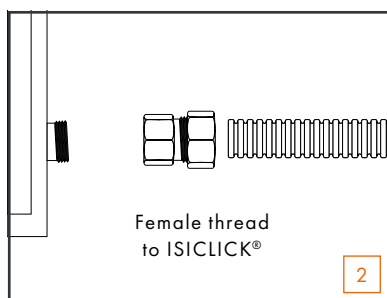

Collector
with pipe end

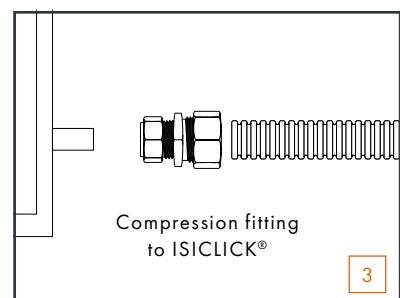



ISICLICK® on ISIKLICK straight

Type	Description	SAP	Pc./📦	RBG	€/Pc.
DN 16	DN 16 x DN 16	3032941	1	AS1	29,62
DN 20	DN 20 x DN 20	3032942	1	AS1	33,11
DN 25	DN 25 x DN 25	3032943	1	AS1	92,61



ISICLICK® with tip

Type	SAP	Pc./📦	RBG	€/Pc.
DN 16 x 15 mm tip	3032952	1	AS1	25,22
DN 16 x 18 mm tip	3032958	1	AS1	20,86
DN 16 x 22 mm tip	3032964	1	AS1	21,47
DN 20 x 18 mm tip	3032959	1	AS1	26,27
DN 20 x 22 mm tip	3032965	1	AS1	28,29
DN 25 x 22 mm tip	3032966	1	AS1	56,56



ISICLICK® T-shaped

Type	SAP	Pc./📦	RBG	€/Pc.
DN 16 x DN 16 x DN 16	3032954	1	AS1	48,89
DN 20 x DN 20 x DN 20	3032955	1	AS1	69,73

ACCESSORIES AEROLINE® inox

Connection set

Reference	Description	SAP	Pc./📦	RBG	€/Pc.
DN 16	4 Union nuts 3/4" 4 Seals 1 Body washer	3032150	1	AS1	30,48
DN 20	4 Union nuts 1" 4 Seals 1 Body washer	3032151	1	AS1	40,13
DN 25	4 Union nuts 1 1/4" 4 Seals 1 Body washer	3041109	1	AS1	62,72
DN 32	4 Union nuts 1 1/2" 4 Seals 1 Body washer	3032153	1	AS1	100,22
DN 40	4 Union nuts 2" 4 Seals 1 Body washer	3032154	1	AS1	190,60

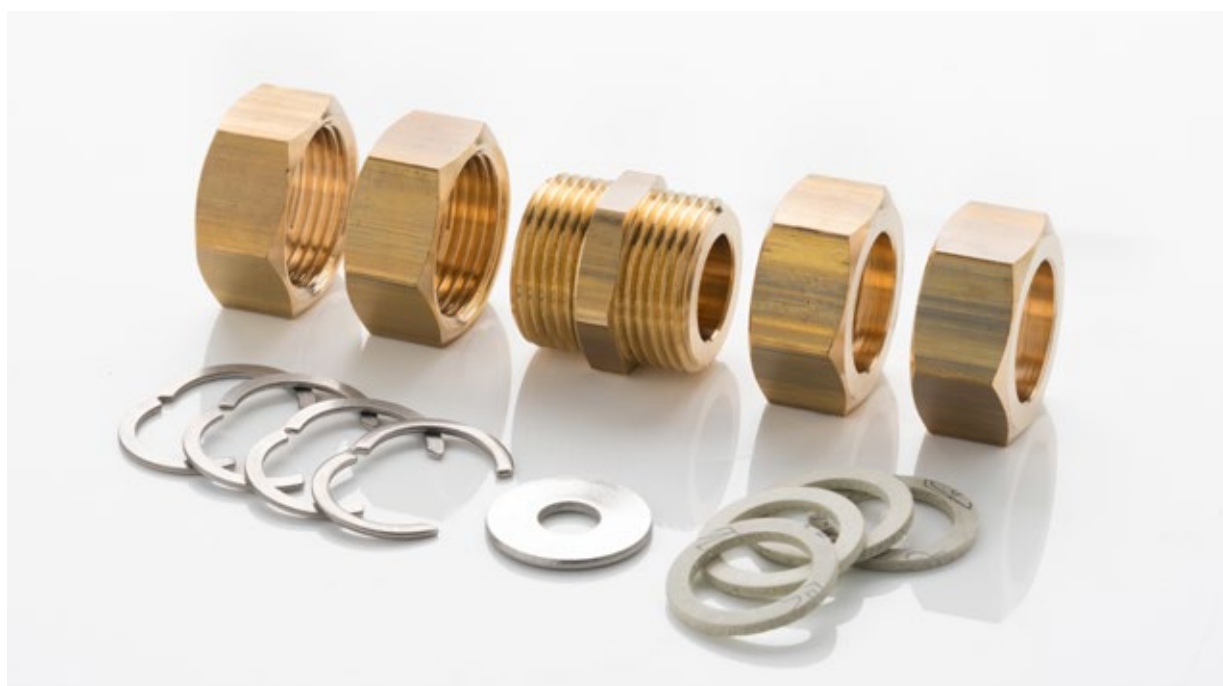



Double nipple

Reference	Description	SAP	Pc./☞	RBG	€/Pc.
3/4" x 3/4"	DN 16	3032926	1	AS1	5,86
1" x 1"	DN 20	3032927	1	AS1	8,67
1 1/4" x 1 1/4"	DN 25	3032928	1	AS1	17,36
1 1/2" x 1 1/2"	DN 32	3032929	1	AS1	21,72
2" x 2"	DN 40	3032930	1	AS1	43,62



Reducing nipple

Reference	Description	SAP	Pc./☞	RBG	€/Pc.
1 1/4" x 1" AG	Male thread	3032968	1	AS1	28,39
1 1/2" x 1 1/4" AG	Male thread	3032969	1	AS1	31,37
2" x 1 1/2" AG	Male thread	3032970	1	AS1	36,63



Reducing piece

Reference	Description	SAP	Pc./☞	RBG	€/Pc.
1 1/4" AG x 1" IG	Male-/female thread	3032967	1	AS1	16,55
1 1/2" AG x 1 1/4" IG	Male-/female thread	3032973	1	AS1	29,62
2" AG x 1 1/2" IG	Male-/female thread	3032974	1	AS1	27,87



AEROLINE® stainless steel double-pipe mounting kit

Reference	Description	SAP	Pc./☞	RBG	€/Pc.
Size 2 for DN 16	4 oval clips 4 hanger bolts M8 x 80 4 dowels S10	3035471	1	AS2	20,05
Size 3 for DN 20 / DN 25 PRO	4 oval clips 4 hanger bolts M8 x 80 4 dowels S10	3028984	1	AS2	22,48
Size 4 for DN 25 SPLIT 100	4 oval clips 4 hanger bolts M8 x 80 4 dowels S10	3035473	1	AS2	28,14
Size 5 for DN 32 PRO GS	4 oval clips 4 hanger bolts M8 x 80 4 dowels S10	3035474	1	AS2	96,70

SOLAR-TUBE®

eco

SEPARABLE STAINLESS STEEL CORRUGATED PIPE SYSTEM, INSULATED WITH HIGH-TEMPERATURE ELASTOMER AND WRAPPED IN PE FILM, FITTED WITH SENSOR CABLE.

TECHNICAL SPECIFICATIONS

SHEATHING

MATERIAL	Polyolefin film
	Very good ozone resistance, UV-resistant

STAINLESS STEEL CORRUGATED PIPE

MATERIAL	Material No. 1.4404 (AISI 316L)
TEMPERATURE RANGE	-270 °C to 600 °C
MAXIMUM PERMISSIBLE OPERATING PRESSURE AT 200 °C	DN 16: 9,8 bar DN 20: 6,1 bar DN 25: 6,1 bar

SENSOR CABLE

2 x 0,75 mm² VDE 7507

INSULATION MADE OF EPDM

MATERIAL	Light, flexible, closed-cell, synthetic rubber. Free of PVC and CFC (according to legal requirements). No embrittlement of copper and stainless steel pipes (DIN 1988 Part 200) Dimensions and tolerances according to DIN EN 14304
TEMPERATURE RANGE	+150 °C, short-term up to +175 °C
THERMAL CONDUCTIVITY	0,036 W/mK at 0 °C 0,038 W/mK at 40 °C
FIRE BEHAVIOUR	Euro class E (DIN EN 13501-1)



SOLAR-TUBE® | eco

Reference	SAP	m/☀	RBG	€/m
DN 16				
DN 16 - 13 mm/10 m	3028945	10	AR5	43,37
DN 16 - 13 mm/15 m	3028946	15	AR5	43,37
DN 16 - 13 mm/20 m	3028947	20	AR5	43,37
DN 16 - 13 mm/25 m	3028948	25	AR5	43,37
DN 16 - 13 mm/50 m	3032473	50	AR5	43,37
DN 20				
DN 20 - 13 mm/10 m	3028949	10	AR5	52,25
DN 20 - 13 mm/15 m	3028950	15	AR5	52,25
DN 20 - 13 mm/20 m	3032483	20	AR5	52,25
DN 20 - 13 mm/25 m	3028951	25	AR5	52,25
DN 20 - 13 mm/50 m	3032484	50	AR5	52,25
DN 25				
DN 25 - 13 mm/10 m	3032492	10	AR5	71,17
DN 25 - 13 mm/15 m	3032493	15	AR5	71,17
DN 25 - 13 mm/20 m	3032494	20	AR5	71,17
DN 25 - 13 mm/25 m	3032495	25	AR5	71,17
DN 25 - 13 mm/50 m	3032496	50	AR5	71,17

Each box contains a mounting kit that includes:
 4 union nuts for 3/4" (DN 16) or 1" (DN 20) or 1 1/4" (DN 25),
 4 clamping washers, 4 seals, 1 DOUBLE NIPPLE, 1 body washer

SOLAR-TUBE®

eco combi

SEPARABLE STAINLESS STEEL CORRUGATED PIPE SYSTEM, INSULATED WITH HIGH-TEMPERATURE ELASTOMER AND WRAPPED IN PE FILM, FITTED WITH SENSOR CABLE.

TECHNICAL SPECIFICATIONS

SHEATHING

MATERIAL	Polyolefine-Folie with additional mounting protection made of robust polyester/stainless steel wire mesh on the collector side (2m) Very good ozone resistance, UV-resistant
----------	---

STAINLESS STEEL CORRUGATED PIPE

MATERIAL	Material No. 1.4404 (AISI 316L)
TEMPERATUREINSATZBEREICH	-270 °C to 600 °C
MAXIMUM PERMISSIBLE OPERATING PRESSURE AT 200°C	DN 16: 9,8 bar DN 20: 6,1 bar

SENSOR CABLE

2 x 0,75 mm² VDE 7507

INSULATION MADE OF EPDM

MATERIAL	Light, flexible, closed-cell, synthetic rubber. Free of PVC and CFC (according to legal requirements). No embrittlement of copper and stainless steel pipes (DIN 1988 Part 200) Dimensions and tolerances according to DIN EN 14304
TEMPERATURE RANGE	+150 °C, short-term up to +175 °C
THERMAL CONDUCTIVITY	0,036 W/mK at 0 °C 0,038 W/mK at 40 °C
FIRE BEHAVIOUR	Euro class E (DIN EN 13501-1)



SOLAR-TUBE® | eco combi

Reference	SAP	m/☀	RBG	€/m
DN 16				
16 x 13/10 m	3052690	10	AR5	43,90
16 x 13/15 m	3052691	15	AR5	43,90
16 x 13/20 m	3052692	20	AR5	43,90
16 x 13/25 m	3052693	25	AR5	43,90
DN 20				
20 x 13/10 m	3052694	10	AR5	52,90
20 x 13/15 m	3052695	15	AR5	52,90
20 x 13/20 m	3052696	20	AR5	52,90
20 x 13/25 m	3052697	25	AR5	52,90

ACCESSORIES SOLAR-TUBE® eco



Connection set

Reference	Description	SAP	Pc./☞	RBG	€/Set
DN 16	4 Union nuts for 3/4" (DN 16) 4 Clamping washers 4 Seals 1 Double nipple 1 Body washer	3028942	1	AS1	29,62
DN 20	4 Union nuts for 1" (DN 20) 4 Clamping washers 4 Seals 1 Double nipple 1 Body washer	3028944	1	AS1	41,87
DN 25	4 Union nuts for 1 1/4" (DN 25) 4 Clamping washers 4 Seals 1 Double nipple 1 Body washer	3032152	1	AS1	62,72



Oval mounting clamps

Reference	Description	SAP	Pc./☞	RBG	€/Set
Size 1 for DN 16	4 clamps 4 hanger bolts 4 dowels	3035470	1	AS2	17,64
Size 2 for DN 20	4 clamps 4 hanger bolts 4 dowels	3035471	1	AS2	20,05
Size 3 for DN 25	4 clamps 4 hanger bolts 4 dowels	3028984	1	AS2	22,48

ACCESSORIES SOLAR-TUBE® eco connect



Metal seal fitting with external thread

Reference	Description	SAP	Pc./☞	RBG	€/Pc.
DN 16	½" AG for DN 16	3032750	1	AS1	27,58
DN 16	¾" AG for DN 16	3032747	1	AS1	28,46
DN 20	¾" AG for DN 20	3032748	1	AS1	32,32
DN 20	1" AG for DN 20	3032751	1	AS1	33,91
DN 25	1" AG for DN 25	3032749	1	AS1	39,84
DN 25	1¼" AG for DN 25	3032752	1	AS1	37,05



Metal seal fitting with internal thread

Reference	Description	SAP	Pc./☞	RBG	€/Pc.
DN 16	½" IG for DN 16	3032756	1	AS1	24,70
DN 16	¾" IG for DN 16	3032753	1	AS1	27,58
DN 20	¾" IG for DN 20	3032754	1	AS1	28,21
DN 20	1" IG for DN 20	3032757	1	AS1	35,39
DN 25	1" IG for DN 25	3032755	1	AS1	53,54



Double metal seal coupling

Reference	Description	SAP	Pc./☞	RBG	€/Pc.
DN 16	Double coupling DN 16	3032744	1	AS1	40,99
DN 20	Double coupling DN 20	3032745	1	AS1	44,85
DN 25	Double coupling DN 25	3032746	1	AS1	67,78



Adapter fitting with clamping ring

Reference	Description	SAP	Pc./☞	RBG	€/Pc.
DN 16	DN 16 x clamping ring 15 mm	3032763	1	AS1	29,33
DN 16	DN 16 x clamping ring 18 mm	3028952	1	AS1	30,77
DN 16	DN 16 x clamping ring 22 mm	3032761	1	AS1	30,77
DN 20	DN 20 x clamping ring 18 mm	3032759	1	AS1	35,39
DN 20	DN 20 x clamping ring 22 mm	3032762	1	AS1	35,39
DN 25	DN 25 x clamping ring 22 mm	3032760	1	AS1	55,09



Adapter fitting with tip

Reference	Description	SAP	Pc./☞	RBG	€/Pc.
DN 16	DN 16 x 18 mm socket	3032766	1	AS1	44,58
DN 16	DN 16 x 22 mm socket	3032764	1	AS1	40,20
DN 20	DN 20 x 22 mm socket	3032765	1	AS1	52,97

AEROLINE®

inox rapid classic

**PRE-INSULATED SINGLE PIPES FOR SOLAR SYSTEM TUBING,
WITH POLYOLEFIN PROTECTIVE FILM**

TECHNICAL SPECIFICATIONS

SHEATHING

MATERIAL Polyolefin film

STAINLESS STEEL CORRUGATED PIPE

MATERIAL Material No. 1.4404 (AISI 316L)

MAXIMUM PERMISSIBLE DN 16: 11 bar DN 32: 6 bar

OPERATING PRESSURE AT 200°C DN 20: 11 bar DN 40: 4,9 bar
DN 25: 10 bar

INSULATION MADE OF EPDM

MATERIAL Light, flexible, closed-cell, synthetic rubber. No embrittlement of copper and stainless steel pipes (DIN 1988 Part 200)
Dimensions and tolerances according to DIN EN 14304

THERMAL CONDUCTIVITY 0,036 W/mK at 0 °C
0,038 W/mK at 40 °C

FIRE BEHAVIOUR Euro class E (DIN EN 13501-1)

TEMPERATURE RANGE +150 °C, short-term up to +175 °C
(EN 14707)



TECHNICAL INSULATION
AEROLINE®

AEROLINE® | inox rapid classic

Reference	SAP	m/📦	RBG	€/m
DN 16				
16 x 13 / 10 m	3032601	10	AR3	25,47
16 x 13 / 25 m	3032602	25	AR3	23,00
16 x 13 / 50 m	3032603	50	AR3	23,00
16 x 25 / 10 m	3032604	10	AR3	34,06
16 x 25 / 25 m	3032605	25	AR3	31,15
16 x 25 / 50 m	3032606	50	AR3	31,15
DN 20				
20 x 13 / 10 m	3032607	10	AR3	29,69
20 x 13 / 25 m	3032609	25	AR3	26,78
20 x 13 / 50 m	3032610	50	AR3	26,78
20 x 25 / 10 m	3032611	10	AR3	37,11
20 x 25 / 25 m	3032613	25	AR3	34,20
20 x 25 / 50 m	3032614	50	AR3	34,20
DN 25				
25 x 19 / 5 m	3053313	5	AR3	41,54
25 x 19 / 10 m	3032616	10	AR3	38,42
25 x 19 / 25 m	3032618	25	AR3	34,78
25 x 19 / 50 m	3032619	50	AR3	34,78
DN 32				
32 x 19 / 5 m	3053314	5	AR3	56,26
32 x 19 / 10 m	3032651	10	AR3	53,12
32 x 19 / 25 m	3032654	25	AR3	49,34
DN 40				
40 x 25 / 5 m	3053315	5	AR3	81,04
40 x 25 / 10 m	3032688	10	AR3	78,59
40 x 25 / 25 m	3032689	25	AR3	75,97

AEROLINE®

inox rapid pro

**PRE-INSULATED SINGLE PIPES FOR SOLAR SYSTEM TUBING,
WITH SOLID MOUNTING AND SURFACE PROTECTION.
IDEAL FOR OUTDOOR USE.**

TECHNICAL SPECIFICATIONS

SHEATHING

MATERIAL	Mounting protection made from strong polyester fabric / stainless steel wire Very good ozone resistance, UV-resistant
----------	--

STAINLESS STEEL CORRUGATED PIPE

MATERIAL	Material No. 1.4404 (AISI 316L)
TEMPERATUREINSATZBEREICH	-270 °C to 600 °C
MAXIMUM PERMISSIBLE OPERATING PRESSURE AT 200°C	DN 16: 11 bar DN 20: 11 bar

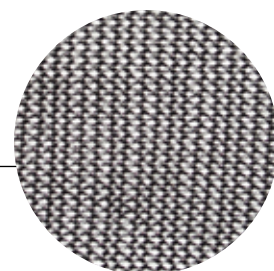

INSULATION MADE OF EPDM

MATERIAL	Light, flexible, closed-cell, synthetic rubber. Free of PVC and CFC (according to legal requirements). No embrittlement of copper and stainless steel pipes (DIN 1988 Part 200) Dimensions and tolerances according to DIN EN 14304
TEMPERATURE RANGE	+150 °C, short-term up to +175 °C (stagnation temperature of collectors)
THERMAL CONDUCTIVITY	0,036 W/mK at 0 °C 0,038 W/mK at 40 °C
FIRE BEHAVIOUR	Euro class E (DIN EN 13501-1)



AEROLINE® | inox rapid pro

Reference	SAP	m/📦	RBG	€/m
DN 16				
16 x 13 / 10 m	3032236	10	AR3	41,48
16 x 13 / 25 m	3032237	25	AR3	36,97
16 x 13 / 50 m	3032238	50	AR3	36,97
16 x 25 / 10 m	3032261	10	AR3	55,89
16 x 25 / 25 m	3032262	25	AR3	51,52
16 x 25 / 45 m	3032263	45	AR3	51,52
DN 20				
20 x 13 / 10 m	3032244	10	AR3	44,25
20 x 13 / 25 m	3032246	25	AR3	40,46
20 x 13 / 50 m	3032247	50	AR3	40,46
20 x 25 / 10 m	3032264	10	AR3	58,80
20 x 25 / 25 m	3032266	25	AR3	54,43
20 x 25 / 45 m	3032267	45	AR3	54,43

AEROLINE®

inox rapid progs

**PRE-INSULATED SINGLE PIPES FOR SOLAR SYSTEM TUBING,
WITH SOLID MOUNTING AND SURFACE PROTECTION.
IDEAL FOR OUTDOOR USE!**

TECHNICAL SPECIFICATIONS

SHEATHING

MATERIAL	Polyester braid
	Very good ozone resistance, UV-resistant

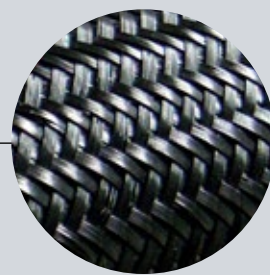

STAINLESS STEEL CORRUGATED PIPE

MATERIAL	Material No. 1.4404 (AISI 316L)
MAXIMUM PERMISSIBLE OPERATING PRESSURE AT 200°C	DN 25: 10 bar DN 32: 6 bar DN 40: 4,9 bar

INSULATION MADE OF EPDM

MATERIAL	Light, flexible, closed-cell, synthetic rubber. No embrittlement of copper and stainless steel pipes (DIN 1988 Part 200). Dimensions and tolerances according to DIN EN 14304
THERMAL CONDUCTIVITY	0,036 W/mK at 0 °C 0,038 W/mK at 40 °C
TEMPERATURE RANGE (EN 14707)	+150 °C, short-term up to +175 °C
FIRE BEHAVIOUR	Euro class E (DIN EN 13501-1)



AEROLINE® | inox rapid progs

Reference	SAP	m/📦	RBG	€/m
DN 25				
25 x 19 / 5 m	3053138	5	AR3	57,23
25 x 19 / 10 m	3032250	10	AR3	53,70
25 x 19 / 25 m	3032251	25	AR3	52,25
25 x 38 / 5 m	3053316	5	AR3	94,61
25 x 38 / 10 m	3032253	10	AR3	94,46
25 x 38 / 25 m	3032254	25	AR3	93,00
DN 32				
32 x 19 / 5 m	3053317	5	AR3	77,34
32 x 19 / 10 m	3032255	10	AR3	76,99
32 x 19 / 25 m	3032256	25	AR3	76,26
32 x 38 / 5 m	3053318	5	AR3	106,24
32 x 38 / 10 m	3032257	10	AR3	106,10
32 x 38 / 25 m	3032258	25	AR3	104,65
DN 40				
40 x 25 / 5 m	3053319	5	AR3	99,28
40 x 25 / 10 m	3032259	10	AR3	98,82
40 x 25 / 25 m	3032260	25	AR3	97,37

ACCESSORIES – AEROLINE® inox rapid pro gs



Mounting clamps

Reference	Description	SAP	Pc./📦	RBG	€/Set
Ø 85 mm for DN 32-19 mm	4 mounting clamps 4 hanger bolts M8 x 80 4 dowels S10	3035469	1	AS2	19,33
Ø 110 mm for DN 25-38 mm/ DN 40-25 mm	4 mounting clamps 4 hanger bolts M8 x 80 4 dowels S10	3032268	1	AS2	27,16
Ø 126 mm for DN 32-38 mm	4 mounting clamps 4 hanger bolts M8 x 80 4 dowels S10	3052372	1	AS2	34,00

Delivery: 2-7 working days ex-works (applies to all references)

NMC sa

Gert-Noël-Strasse · B-4731 Eynatten

+32 87 85 85 00 · +32 87 85 85 11

info@nmc.eu



www.nmc-insulation.com